

Pulsation Dampener PD8100 Series

The PD8100 Series eliminates pointer flutter on pressure indicating gage devices which are subject to pulsating pressure from reciprocating pumps or compressors. It also allows a close setting of high and low contact points providing for more accurate pressure indication and control of equipment.

The PD8100 Series decreases wear on geared movements and increases the life of pressure indicating instruments by eliminating excessive gage strain and unnecessary movement, a necessity which quickly pays for itself by protecting any pressure indicating and control instrument which is subject to pulsation.

PD8100 SERIES IS NOT FOR USE ON OXYGEN OR LIQUID OXYGEN APPLICATIONS.

The PD8100 is quality built with a large diameter valve stem wheel for ease of adjustment and features clearly printed operating instructions.

Machined from 1 3/8-inch (35 mm) hex bar stock, a two degree taper on the valve and stem assure positive dampening.

It's available in brass, carbon steel, 303 stainless steel or 316 stainless steel to meet pressure and environmental requirements with either 1/2 NPT or 1/4 NPT inlet connections.

Dimensions

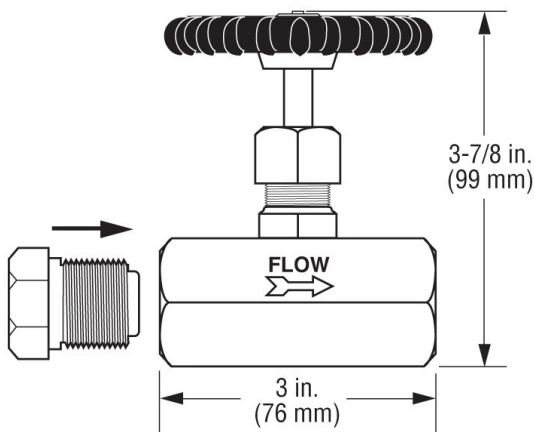

Specifications

See How to Order section for available inlet and outlet connections.

PD8183: All wetted parts are brass. Rated to 3000 psi (20.68 MPa) [206.80 bar].

PD8184: All wetted parts are carbon steel. Rated to 5000 psi (34.47 MPa) [344.70 bar].

PD8185: All wetted parts are 303 stainless steel. Rated to 10000 psi (68.95 MPa) [689.50 bar]. Meets NACE standard MR- 01-75 for direct exposure to HS.

Operating Temperature: -15° to 400° F (-26° to 204° C)

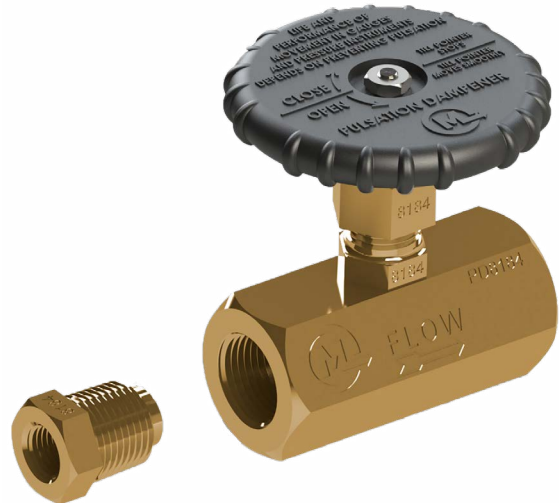

NOT INTENDED FOR USE AS A SHUTOFF VALVE

Compressor Panel

The PDs are recommended for use on piston pumps and compressors to eliminate pointer contact flutter and gage wear.

Shown is a typical compressor panel featuring three PDs and FW Murphy OPLFC gages.



Mounting

The PD8100 Series Pulsation Dampener is mounted directly below the OPLFS Pressure Gage.

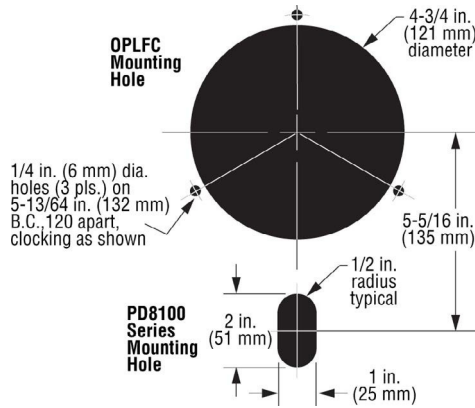

Precautions: Do not block the inlet orifice. Use caution when applying dope or Teflon tape on connection threads.

Diagram

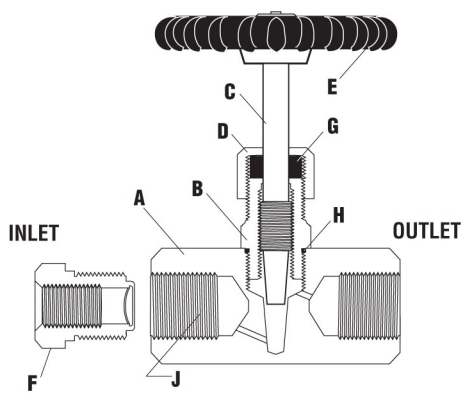

A. 1/2 NPT inlet x 1/4 NPT outlet*
A. 1/2 NPT x 1/2 NPT outlet*
B. Bonnet Fitting
C. Valve Stem
D. Packing Nut
E. Hand Wheel (with 10-32 nut)
F. Strainer Bushing Assembly†
G. Molded Packing Gland
H. O Ring Bonnet Seal
J. Stainless Mesh Filter**

*For 1/4 NPT inlet use with strainer bushing assembly

†Provided only for units with 1/4 NPT inlet

**Provided in units with 1/2 NPT inlet.

How to Order

Options listed below. All configurations may not be available. Call your sales representative or FW Murphy for more information.

PD8185 - 1/4 x 1/4

Base Model	
PD8183	=Brass wetted parts, Rated to 3000 psi (20.68 MPa) [206.90 bar]
PD8184	=Carbon Steel wetted parts, Rated to 5000 psi (34.47MPa) [344.70 bar]
PD8185	=303 Stainless Steel wetted parts, Rated to 10000 psi (68.95 MPa) [689.50 bar]

Connection Size	
1/4 x 1/4	= 1/4 NPT Inlet x 1/4 NPT Outlet
1/4 x 1/2	= 1/4 NPT Inlet x 1/2 NPT Outlet (PD8183, PD8184 only)
1/2 x 1/2	= 1/2 NPT Inlet x 1/2 NPT Outlet
1/2 x 1/4	= 1/2 NPT Inlet x 1/4 NPT Outlet (PD8183, PD8184 only)

Approximate Shipping Weight and Dimensions		
Model Weight Dimension		
All models	2 lb. 0 oz.	4 3/4 x 4 3/4 x 3 1/4 in.

Part Number				Description	Notes
PD8183	PD8184	PD8185	PD8190		
55000179	55000179	55000179	55000179	Hand Wheel (with 10-32 nut)	Service Parts
55000174	55000173	55000175	-----	Strainer Bushing Assembly†	



CONTACT

sales@rajkotmarinelc.ae
+971 6 7487580
www.rajkotmarine.com

RAJKOT MARINE LLC

Jerf Industrial Area 1,
P.O Box 5861
Ajman, UAE

